

# Surface Mount Superfast Recovery Rectifier

## Feature

- For surface mounted applications
- Low profile package
- Glass Passivated Chip Junction
- Superfast reverse recovery time
- Lead free in comply with EU RoHS 2011/65/EU directives

**SMBF (Top View)**

## Mechanical Characteristics

- Case: SMBF
- Terminals : Solderable per MIL-STD-750, Method 2026
- Approx. Weight: 57mg /0.002oz

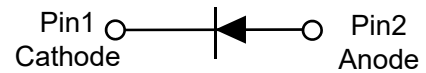
**Circuit Diagram**

## Maximum Ratings and Electrical characteristics

Ratings at 25°C ambient temperature unless otherwise specified. Single phase, half wave, 60 Hz, resistive or inductive load. For capacitive load, derate current by 20%.

Parameter	Symbol	PES5A BF	PES5B BF	PES5C BF	PES5D BF	PES5E BF	PES5G BF	PES5J BF	Units
Maximum Repetitive Peak Reverse Voltage	$V_{RRM}$	50	100	150	200	300	400	600	V
Maximum RMS voltage	$V_{RMS}$	35	70	105	140	210	280	420	V
Maximum DC blocking voltage	$V_{DC}$	50	100	150	200	300	400	600	V
Maximum Average Forward Rectified Current at $T_c=115^\circ\text{C}$	$I_{F(AV)}$	5.0							A
Peak Forward Surge Current 8.3 ms Single Half Sine Wave Superimposed on Rated Load	$I_{FSM}$	150							A
Maximum Forward Voltage at 5 A	$V_F$	1.0				1.25		1.7	V
Maximum DC Reverse Current at Rated DC Blocking Voltage	$T_a=25^\circ\text{C}$	10							$\mu\text{A}$
	$T_a=125^\circ\text{C}$	100							
Typical Junction Capacitance at $V_R=4\text{V}, f=1\text{MHz}$	$C_J$	50							pF
Maximum Reverse Recovery Time <sup>1)</sup>	$t_{rr}$	35							ns
Typical Thermal Resistance <sup>2)</sup>	$R_{\theta JA}$	40							$^\circ\text{C/W}$
	$R_{\theta JC}$	12							
Operating and Storage Temperature Range	$T_J, T_{stg}$	-55~+150							$^\circ\text{C}$

Notes:

- 1) Measured with  $I_F = 0.5\text{ A}$ ,  $I_R = 1\text{ A}$ ,  $I_{rr} = 0.25\text{ A}$ .
- 2) P.C.B. mounted with 2.0" X 2.0" (5 X 5 cm) copper pad areas.

## Typical Characteristics

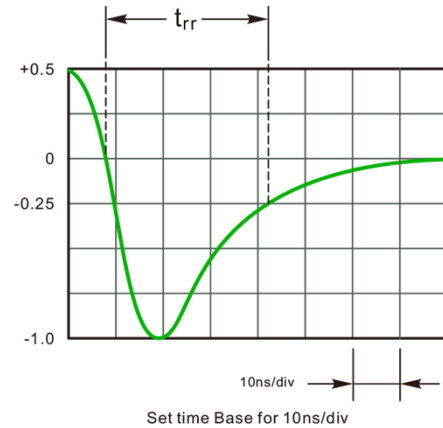
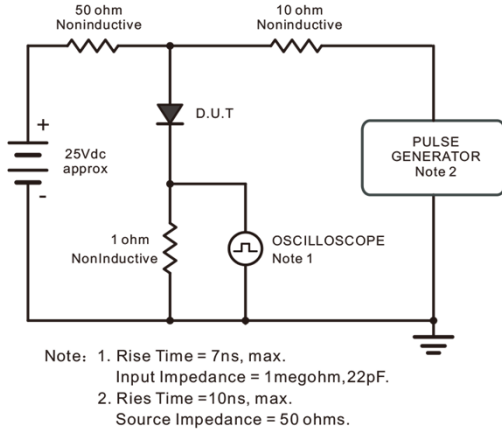

Fig.1 Reverse Recovery Time Characteristic And Test Circuit Diagram

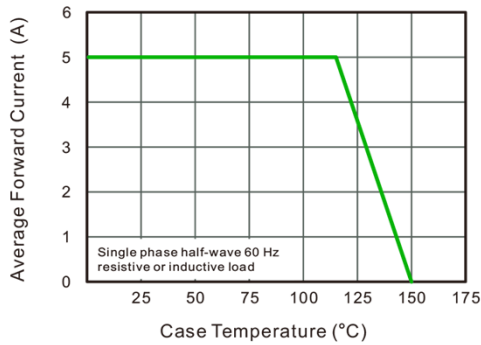

Fig.2 Maximum Average Forward Current Rating

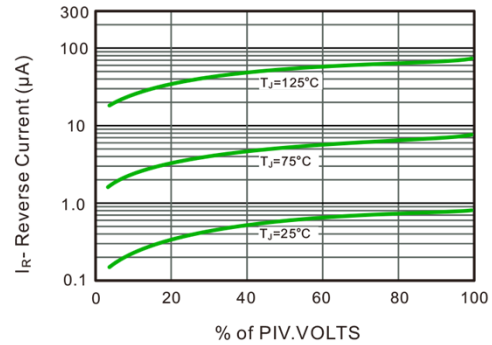

Fig.3 Typical Reverse Characteristics

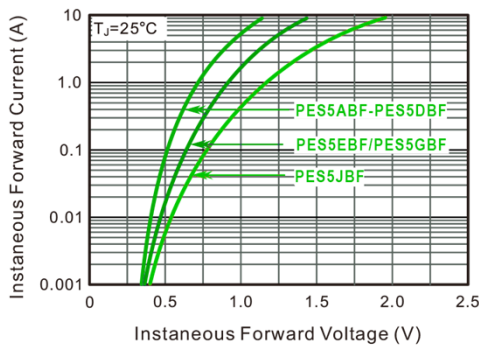

Fig.4 Typical Forward Characteristics

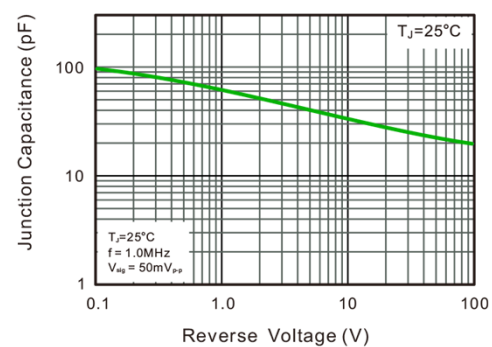

Fig.5 Typical Junction Capacitance

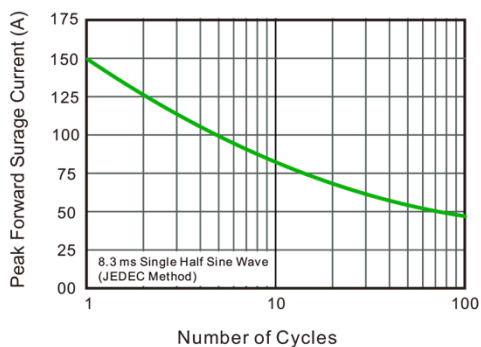
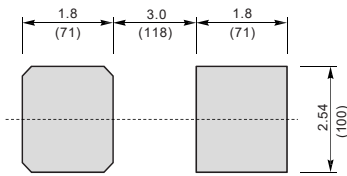
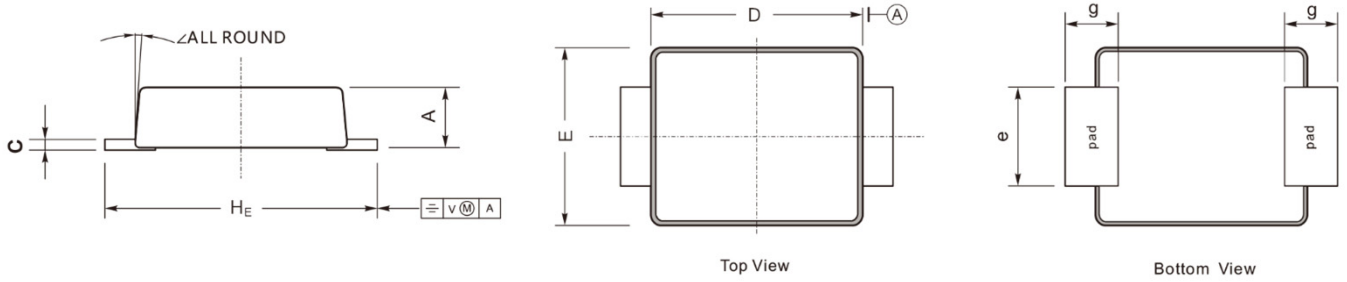

Fig.6 Maximum Non-Repetitive Peak Forward Surge Current

# Surface Mount Superfast Recovery Rectifier

# PES5ABF~PES5JBF

## Product Dimension (SMBF)



Suggested PCB Layout

Unit: mm

Dim	Millimeters		Inches	
	Min	Max	Min	Max
A	1.10	1.30	0.043	0.051
C	0.18	0.26	0.007	0.010
D	4.20	4.40	0.165	0.173
E	3.50	3.70	0.138	0.146
$H_E$	5.10	5.50	0.201	0.217
e	1.90	2.20	0.075	0.087
g	1.00		0.039	
$\angle$	9°		9°	

## Ordering information

Device	Package	Reel	Shipping
PES5ABF~PES5JBF	SMBF	13"	5000 / Tape & Reel

## Marking information

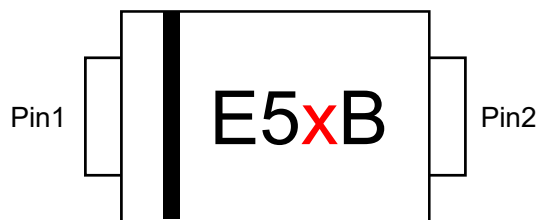

Device	Marking
PES5ABF	E5AB
PES5BBF	E5BB
PES5CBF	E5CB
PES5DBF	E5DB
PES5EBF	E5EB
PES5GBF	E5GB
PES5JBF	E5JB

Load with information

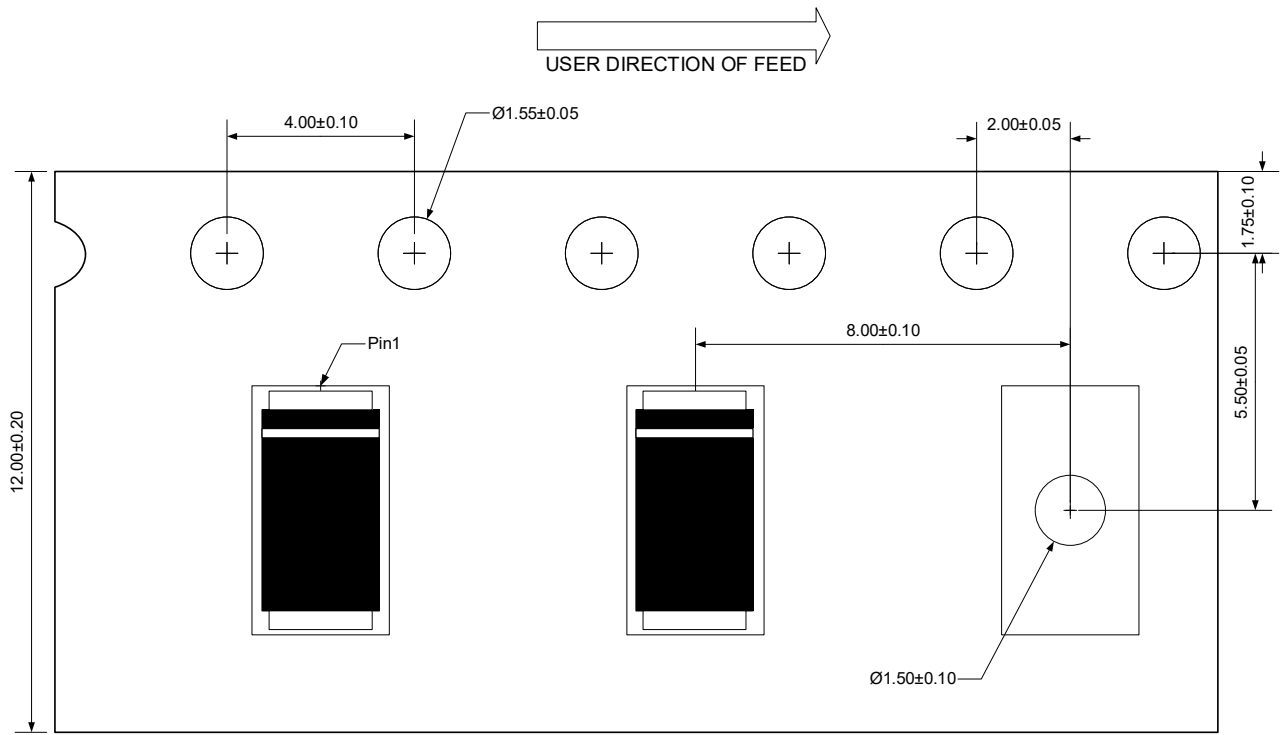

Unit:mm

**IMPORTANT NOTICE**

 and **Prisemi**<sup>®</sup> are registered trademarks of **Prisemi Electronics Co., Ltd** (Prisemi), Prisemi reserves the right to make changes without further notice to any products herein. Prisemi makes no warranty, representation or guarantee regarding the suitability of its products for any particular purpose, nor does Prisemi assume any liability arising out of the application or use of any product or circuit, and specifically disclaims any and all liability, including without limitation special, consequential or incidental damages. “Typical” parameters which may be provided in Prisemi data sheets and/or specifications can and do vary in different applications and actual performance may vary over time. All operating parameters, including “Typicals” must be validated for each customer application by customer’s technical experts. Prisemi does not convey any license under its patent rights nor the rights of others. The products listed in this document are designed to be used with ordinary electronic equipment or devices, Should you intend to use these products with equipment or devices which require an extremely high level of reliability and the malfunction of with would directly endanger human life (such as medical instruments, aerospace machinery, nuclear-reactor controllers, fuel controllers and other safety devices), please be sure to consult with our sales representative in advance.

Website: <http://www.prisemi.com>

For additional information, please contact your local Sales Representative.

©Copyright 2009, Prisemi Electronics

 **Prisemi**<sup>®</sup> is a registered trademark of Prisemi Electronics.

All rights are reserved.