

40V BiGaN Enhancement-mode FET
Description

40V Normally-OFF GaN			
$V_{DS}(V)$	$R_{DD(on)}(m\Omega)$	$I_D(A)$	$Q_G(nC)$
40	12	10	6.3

Feature

- Bi-directional blocking capability
- GaN-on-Silicon E-mode HEMT technology
- Ultra-low on Resistance
- Package: WLCSP 1.2x1.7

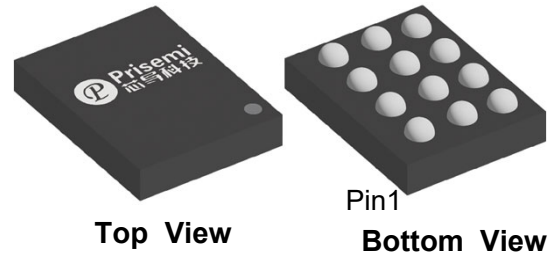
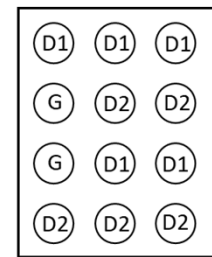

Pin1

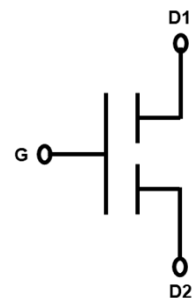
Bottom View

Circuit Diagram
Applications

- High side load switch
- OVP protection in smart phone USB port
- Switch circuits in multiple power suppliers system

Absolute maximum rating@25°C

Rating	Symbol	Value	Units
Drain1-Drain2 Voltage or Drain2-Drain1 Voltage	V_{DD}	40	V
Continuous Drain Current	I_D	10	A
Pulsed Drain Current ($T_c=25^\circ C$, t_p limited by T_{jmax})	$I_{D(pulse)}$	50	A
Power dissipation ($T_{c, board} = 25^\circ C$)	P_{tot}	11	W
Drain-Gate Voltage	V_{DG}	40	V
Gate-Drain Voltage	V_{GD}	6	V
Operating Temperature	T_J	-40 to 125	$^\circ C$
Storage Temperature	T_{STG}	-40 to 150	$^\circ C$

Thermal characteristics

Parameter	Symbol	Min.	Typ.	Max.	Units
Thermal Resistance, Junction-to-Case (top)	$R_{\theta JC_top}$	-	1.44	-	$^\circ C/W$
Thermal Resistance, Junction-to-Case (bottom)	$R_{\theta JC_bot}$	-	8.98	-	$^\circ C/W$
Thermal Resistance, Junction-to-Ambient	$R_{\theta JA}$	-	65.74	-	$^\circ C/W$

Electrical characteristics per line@25°C (unless otherwise specified)

Parameter	Symbol	Conditions	Min.	Typ.	Max.	Units
Drain1-Drain2 Breakdown Voltage	BV_{D1D2S}	$V_G = V_{D2} = 0V, I_{D1D2} = 500\mu A$	40	-	-	V
Drain1-Drain2 Breakdown Voltage	BV_{D2D1S}	$V_G = V_{D1} = 0V, I_{D2D1} = 500\mu A$	40	-	-	V
Gate Threshold Voltage	$V_{GD1(th)}$	$V_{D2} = V_G, V_{D1} = 0V, I_{D2D1} = 1mA$	0.8	-	2.4	V
Gate Threshold Voltage	$V_{GD2(th)}$	$V_{D1} = V_G, V_{D2} = 0V, I_{D1D2} = 1mA$	0.8	-	2.4	V
Zero Gate Voltage Drain Current	I_{D1D2S}	$V_{D1} = 40V, V_G = V_{D2} = 0V$	-	-	20	μA
Zero Gate Voltage Drain Current	I_{D2D1S}	$V_{D2} = 40V, V_G = V_{D1} = 0V$	-	-	20	μA
Gate-Source Leakage Current	I_{GDS}	$V_G = 5V, V_{D1} = V_{D2} = 0V$	-	-	5.0	μA
		$V_G = -5V, V_{D1} = V_{D2} = 0V$	-1.0	-	-	
Gate-Source Leakage Current	I_{GDS}	$V_G = 6V, V_{D1} = V_{D2} = 0V$	-	-	30	μA
		$V_G = -6V, V_{D1} = V_{D2} = 0V$	-1.0	-	-	
Drain1-Drain2 On-State Resistance	$R_{D1D2(ON)}$	$V_{GD2} = 5V, I_{D1D2} = 5A$	-	12	15	m Ω
Drain2-Drain1 On-State Resistance	$R_{D2D1(ON)}$	$V_{GD1} = 5V, I_{D2D1} = 5A$	-	12	15	m Ω
Input Capacitance	C_{iss}	$V_G = 0V, V_D = 20V$	-	306	-	pF
Output Capacitance	C_{oss}		-	162	-	
Reverse Transfer Capacitance	C_{rss}		-	87	-	
Total Gate Charge	Q_G	$V_G = 5V, V_D = 20V, I_D = 10A$	-	6.3	-	nC
Gate-Drain1 Charge	Q_{GD1}	$V_{D2D1} = 20V, I_D = 10A$	-	0.7	-	
Gate-Drain2 Charge	Q_{GD2}	$V_{D2D1} = 20V, I_D = 10A$	-	3.4	-	
Gate-Drain2 Charge	Q_{GD2}	$V_{D1D2} = 20V, I_D = 10A$	-	0.7	-	
Gate-Drain1 Charge	Q_{GD1}	$V_{D1D2} = 20V, I_D = 10A$	-	3.4	-	
Output Charge	Q_{OSS}	$V_G = 0V, V_D = 20V$	-	5.1	-	
Gate Resistance	R_G	f=1MHz	-	2.5	-	Ω

Typical Characteristics

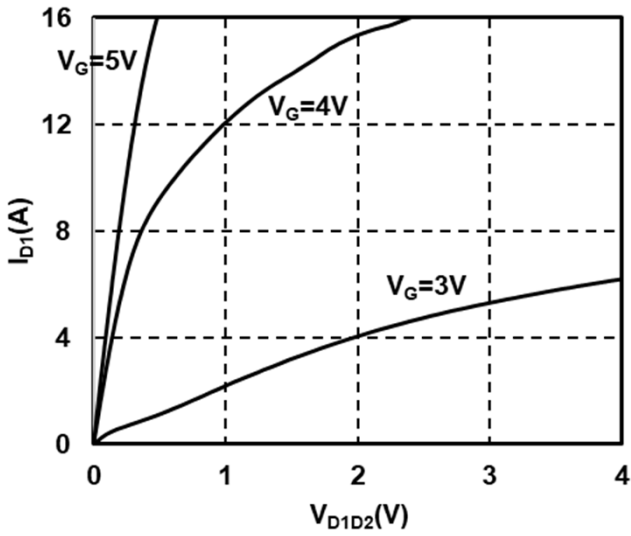

Fig.1 Output Characteristics ($T_J = 25\text{ }^\circ\text{C}$)

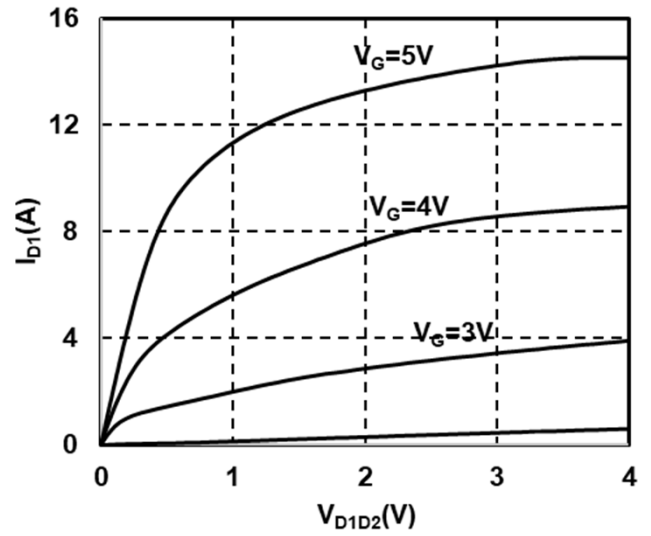

Fig.2 Output Characteristics ($T_J = 125\text{ }^\circ\text{C}$)

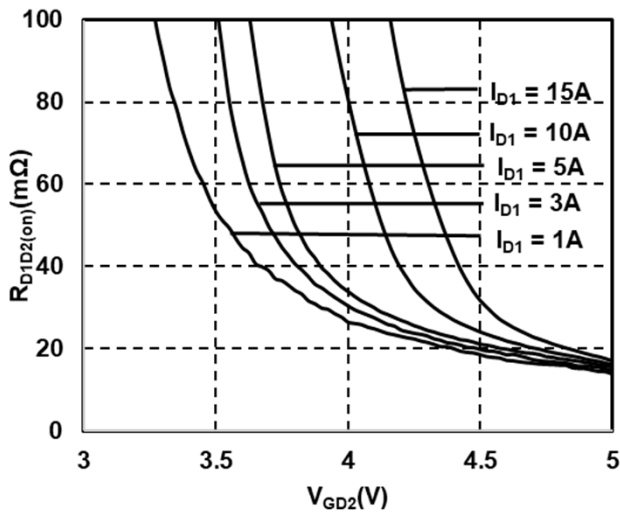

Fig.3 Typical Drain On-state Resistance

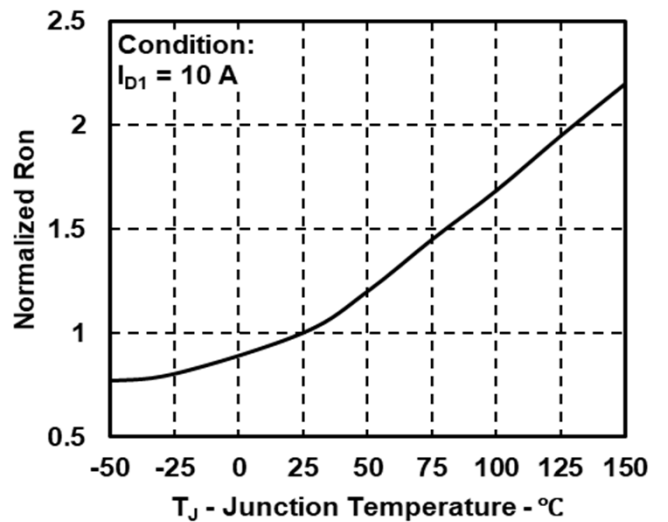

Fig.4 Normalized On Resistance vs. Temperature

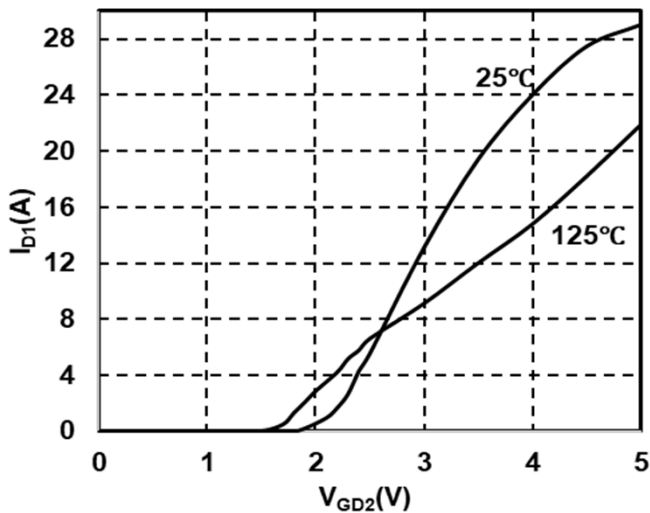

Fig.5 Typical Transfer Characteristics

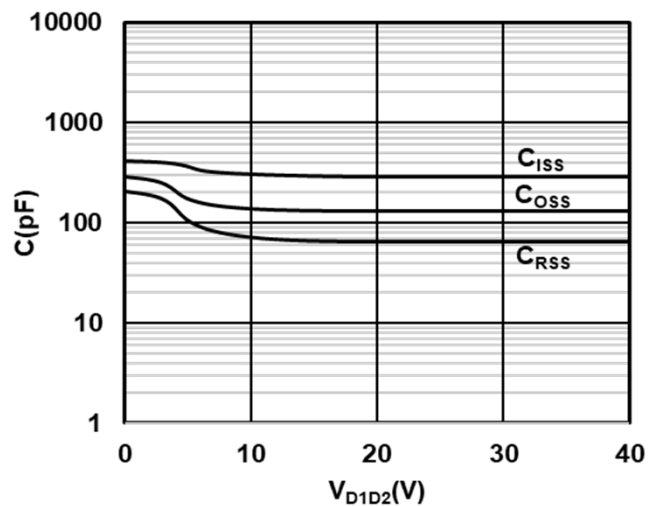

Fig.6 Typical Junction Capacitance

Typical Characteristics

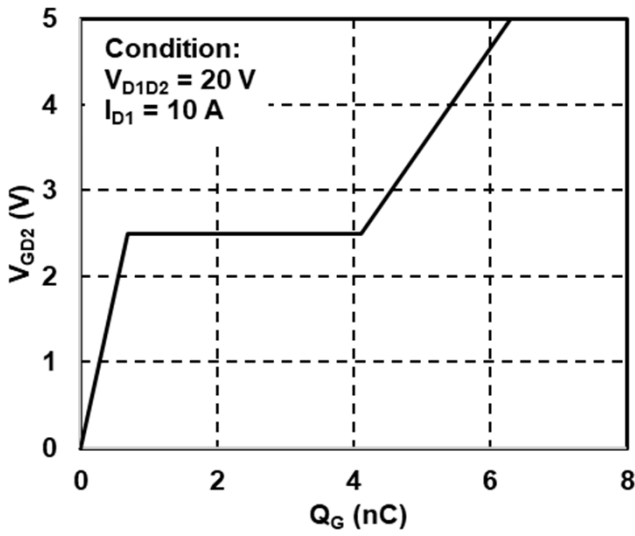

Fig.7 Typ. Gate Charge

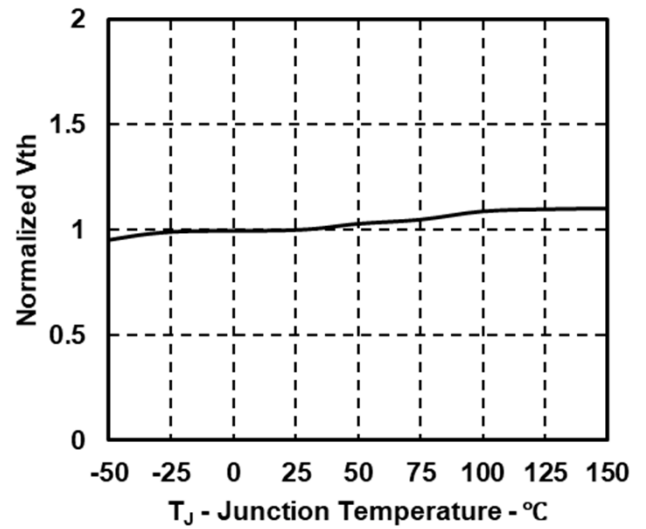

Fig.8 Normalized Threshold Voltage vs. Temp.

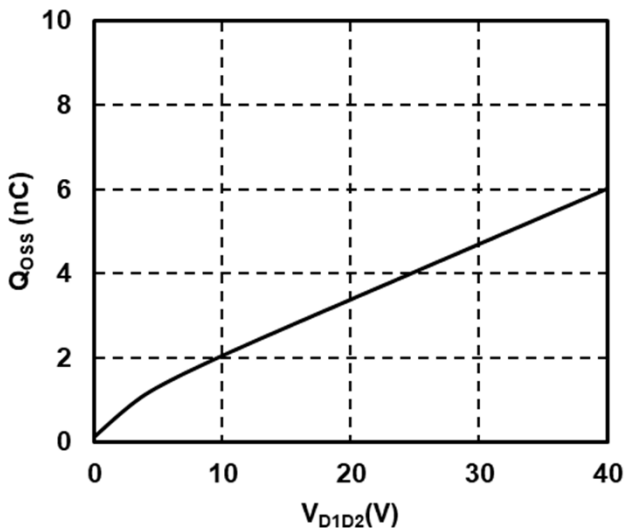

Fig.9 Output Capacitance Stored Energy

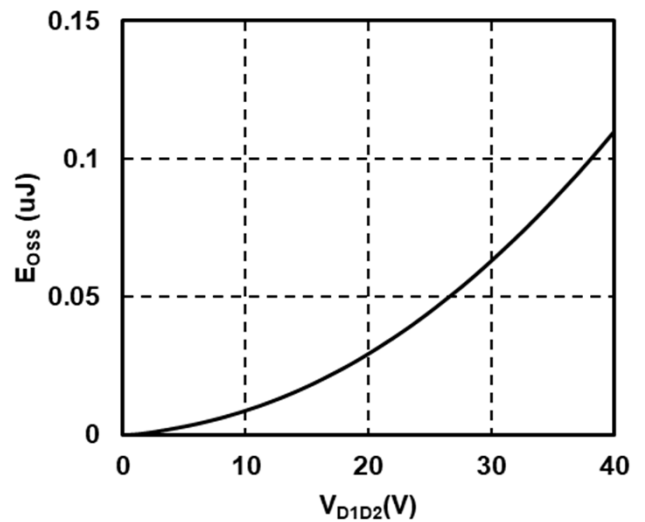

Fig.10 Output Capacitance Stored Energy

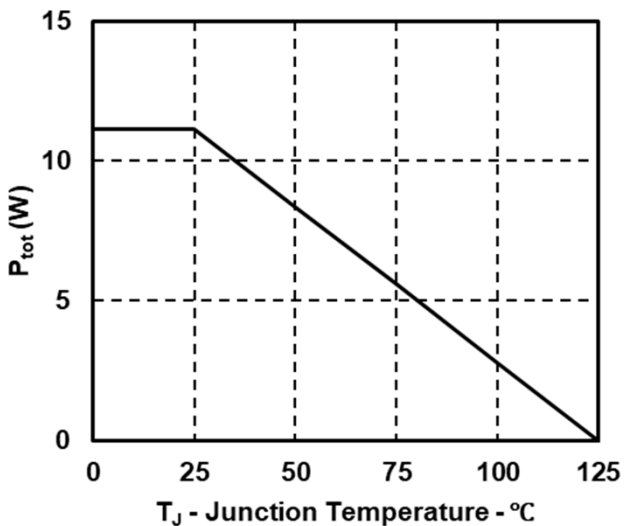

Fig.11 Output Capacitance Stored Energy

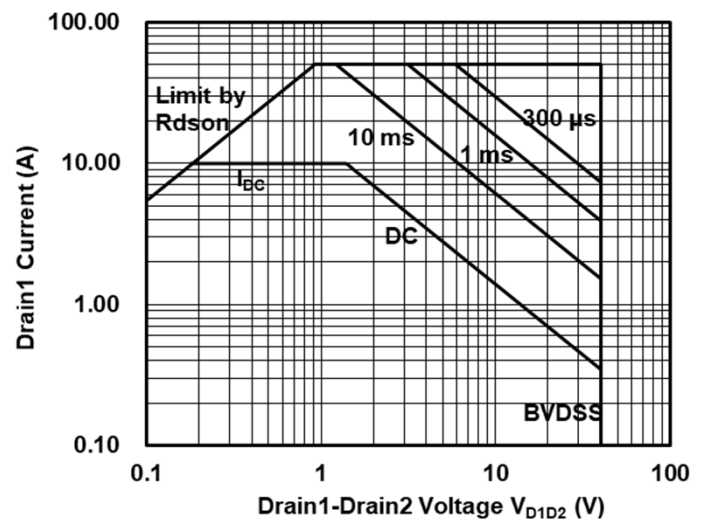

Fig.12 Safe Operating Area

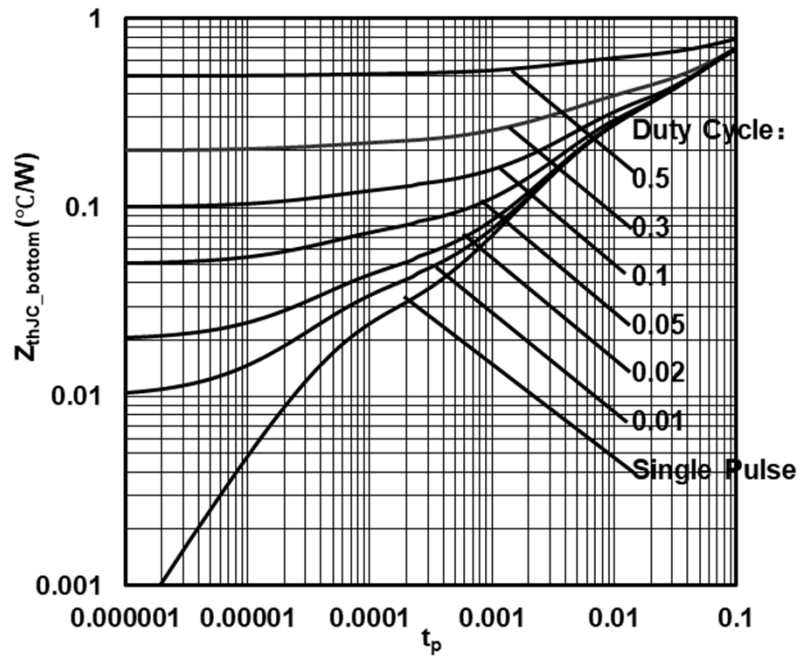
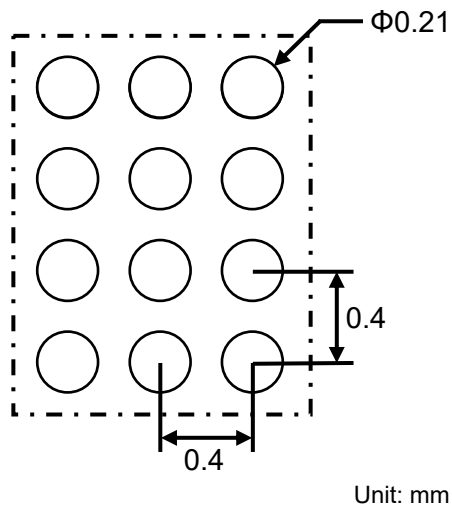
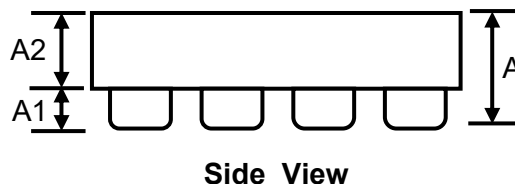
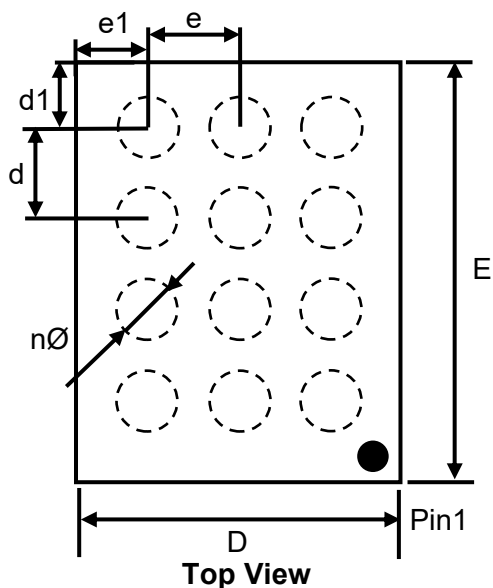

Fig.13 Max. Transient Thermal Impedance

Product Dimension (WLCSP 1.2x1.7)



Suggested PCB Layout

Unit: mm

Dim	Millimeters			Inches		
	Min	Nom	Max	Min	Nom	Max
A	0.518	0.564	0.611	0.0204	0.0222	0.0241
A1	0.193	0.215	0.237	0.0076	0.00846	0.00933
A2	0.325	0.349	0.374	0.0128	0.0137	0.0147
Ø	0.235	0.261	0.287	0.00925	0.0103	0.0113
E	1.68	1.7	1.72	0.0661	0.0669	0.0677
D	1.18	1.2	1.22	0.0465	0.0472	0.048
d	0.4 Ref.			0.0157 Ref.		
d1	0.27 Ref.			0.0106 Ref.		
e	0.4 Ref.			0.0157Ref.		
e1	0.22 Ref.			0.00866 Ref.		

Ordering Information

Device	Package	Reel	Shipping
PGH12BP04R12	WLCSP 1.2x1.7	7"	3000 / Tape & Reel

Load With Information

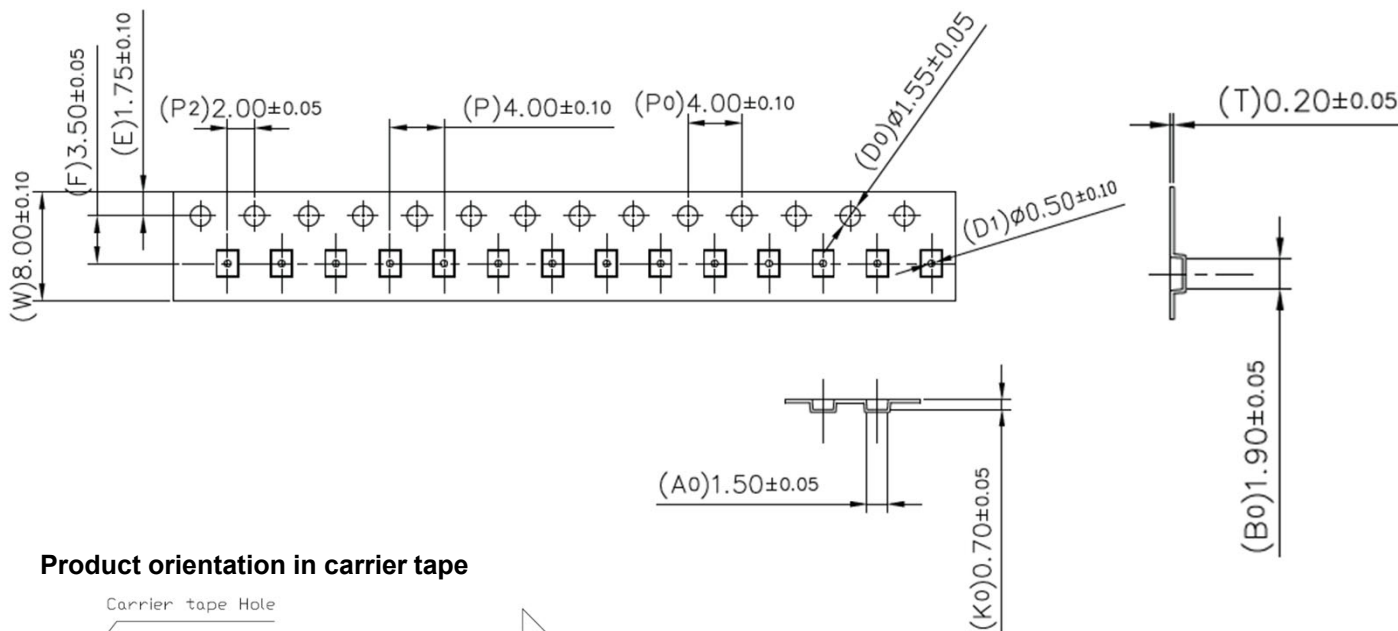

Product orientation in carrier tape

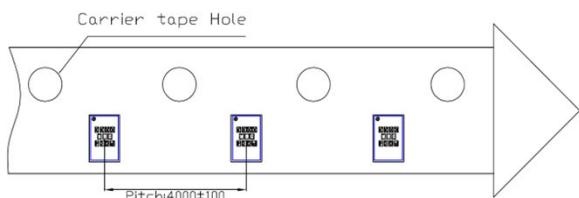

Marking Information

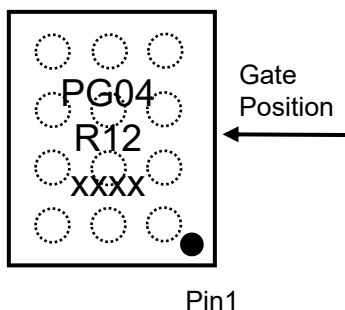

IMPORTANT NOTICE

 and **Prisemi**[®] are registered trademarks of **Prisemi Electronics Co., Ltd** (Prisemi), Prisemi reserves the right to make changes without further notice to any products herein. Prisemi makes no warranty, representation or guarantee regarding the suitability of its products for any particular purpose, nor does Prisemi assume any liability arising out of the application or use of any product or circuit, and specifically disclaims any and all liability, including without limitation special, consequential or incidental damages. "Typical" parameters which may be provided in Prisemi data sheets and/or specifications can and do vary in different applications and actual performance may vary over time. All operating parameters, including "Typicals" must be validated for each customer application by customer's technical experts. Prisemi does not convey any license under its patent rights nor the rights of others. The products listed in this document are designed to be used with ordinary electronic equipment or devices, Should you intend to use these products with equipment or devices which require an extremely high level of reliability and the malfunction of with would directly endanger human life (such as medical instruments, aerospace machinery, nuclear-reactor controllers, fuel controllers and other safety devices), please be sure to consult with our sales representative in advance.

Website: <http://www.prisemi.com>

For additional information, please contact your local Sales Representative.

©Copyright 2009, Prisemi Electronics

 **Prisemi**[®] is a registered trademark of Prisemi Electronics.

All rights are reserved.