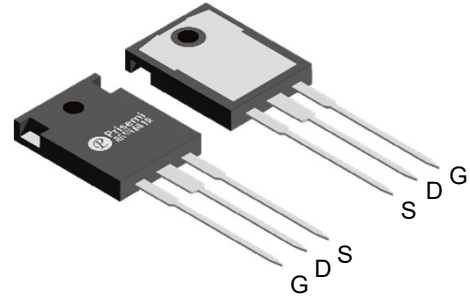

Description

MOSFET Product Summary		
$V_{DS}(V)$	$R_{DS(on)}(m\Omega)$	$I_D(A)$
650	12@ $V_{GS} = 18V$	150

TO-247-3L (Top View)
Feature

- High Speed Switching with Low Capacitances
- High Blocking Voltage with Low $R_{DS(on)}$
- Easy to parallel and simple to drive
- ROHS Compliant, Halogen free

Applications

- EV motor drive
- High Voltage DC/DC Converters
- Switch Mode Power Supplies
- Solar inverters
- EV charging

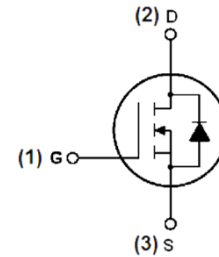
Schematic diagram
Absolute maximum rating@25°C

Parameter	Symbol	Rating	Unit
Drain-Source Voltage	V_{DS}	650	V
Gate-Source Voltage	V_{GS}	-10/+22	V
Continuous Drain Current	I_D	$T_C=25^\circ C$	150
		$T_C=100^\circ C$	100
Pulsed Drain Current	I_{DM}	300	A
Power Dissipation	P_D	550	W
Operating Junction Temperature	T_J	-55 to +175	°C
Storage Temperature	T_{STG}	-55 to +175	°C

Thermal Resistance

Parameter	Symbol	Rating	Unit
Thermal Resistance, Junction-to-Case	$R_{\theta JC}$	0.28	°C/W
Thermal Resistance, Junction-to-Ambient	$R_{\theta JA}$	40	°C/W

Electrical characteristics per line@25°C (unless otherwise specified)

Parameter	Symbol	Conditions	Min.	Typ.	Max.	Units
Statistic Characteristics						
Drain-Source Breakdown Voltage	BV_{DSS}	$V_{GS} = 0V, I_D = 250\mu A$	650	-	-	V
Zero Gate Voltage Drain Current	I_{DSS}	$V_{DS} = 650V, V_{GS} = 0V$	-	-	100	μA
Gate-Body Leakage Current	I_{GSS}	$V_{GS} = -10 \text{ to } 20V,$ $V_{DS} = 0V$	-	-	250	nA
Gate Threshold Voltage	$V_{GS(th)}$	$V_{DS} = V_{GS}, I_D = 22mA$	2.0	3.0	4.0	V
Recommended turn-on Voltage	V_{GSon}	Static	-	18	-	V
Recommended turn-off Voltage	V_{GSoff}		-	-5.0	-	
Drain-Source On-State Resistance	$R_{DS(on)}$	$V_{GS} = 18V, I_D = 75A$	-	12	20	m Ω
		$V_{GS} = 18V, I_D = 75A$ $T_J = 175^\circ C$	-	16	-	
Dynamic Characteristics						
Input Capacitance	C_{iss}	$V_{DS} = 400V,$ $f = 1MHz, V_{AC} = 25mV$	-	7169	-	pF
Output Capacitance	C_{oss}		-	325	-	
Reverse Transfer Capacitance	C_{rss}		-	31	-	
Transconductance	g_{fs}	$V_{DS} = 20V, I_D = 50A$	-	42	-	S
C_{OSS} Stored Energy	E_{OSS}	$V_{DS} = 400V, f = 1MHz$	-	32	-	μJ
Turn-On Energy (Body Diode)	E_{on}	$V_{DS} = 400V, I_D = 50A$ $V_{GS} = -5/+20V,$ $L = 60\mu H, T_J = 175^\circ C$	-	1565	-	μJ
Turn-Off Energy (Body Diode)	E_{off}		-	800	-	
Turn-on Delay Time	$t_{d(on)}$	$V_{DS} = 400V, I_D = 50A$ $V_{GS} = -5/+20V,$ $R_{ext} = 5\Omega, L = 60\mu H$	-	25	-	ns
Turn-on Rise Time	t_r		-	136	-	
Turn-Off Delay Time	$t_{d(off)}$		-	63	-	
Turn-Off Fall Time	t_f		-	27	-	
Total Gate Charge	Q_g	$V_{DS} = 400V, I_D = 50A,$ $V_{GS} = -5/+20V$	-	236	-	nC
Gate-Source Charge	Q_{gs}		-	56	-	
Gate-Drain Charge	Q_{gd}		-	64	-	
Internal Gate Resistance	$R_{G(int)}$	$f = 1MHz, V_{AC} = 25mV$	-	3.5	-	Ω
Reverse Diode Characteristics						
Forward Voltage	V_{FSD}	$V_{GS} = 0V, I_F = 50A$	-	3.5	6.0	V
		$V_{GS} = 0V, I_F = 50A$ $T_J = 175^\circ C$	-	3.0	6.0	
Reverse Recovery Time	t_{rr}	$V_R = 400V, V_{GS} = -5V,$ $I_F = 50A, T_J = 175^\circ C$ $di/dt = 2400A/\mu s$	-	88	-	ns
Reverse Recovery Charge	Q_{rr}		-	680	-	nC
Peak Reverse Recovery Current	I_{mm}		-	17	-	A
Continuous Diode Forward Current	I_S	$V_{GS} = 0V$	-	80	-	A

Typical Characteristics

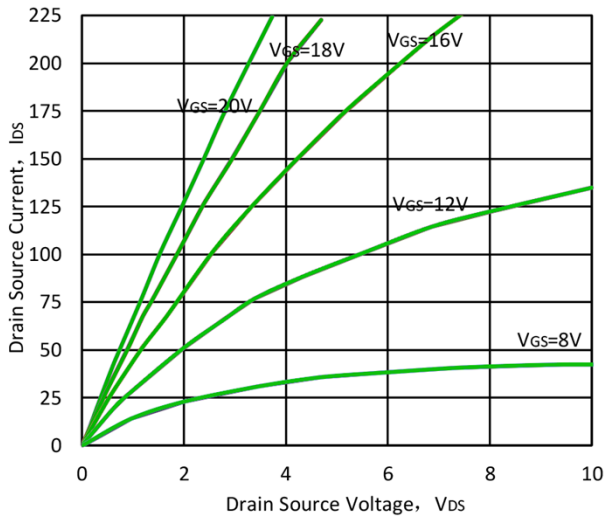

Fig1. Output characteristics ($T_J = 25\text{ }^\circ\text{C}$)

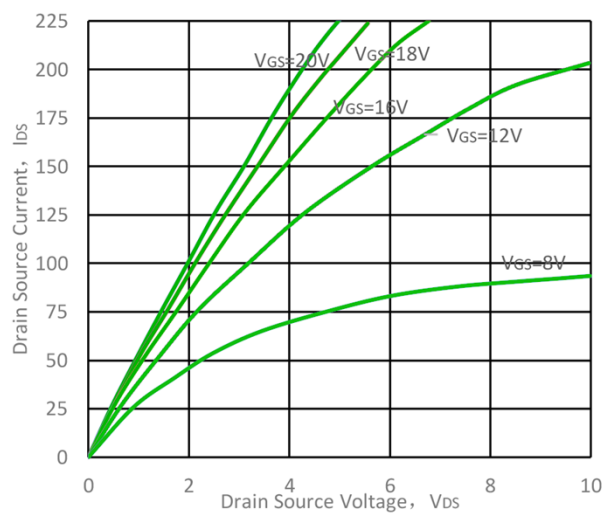

Fig2. Output characteristics ($T_J = 175\text{ }^\circ\text{C}$)

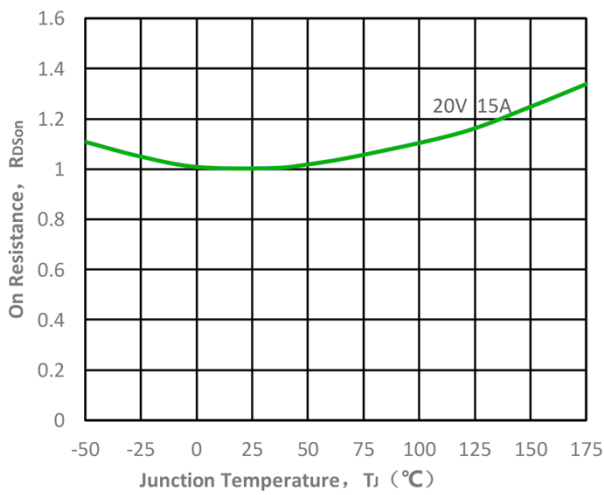

Fig3. Normalized On-Resistance vs. Temperature

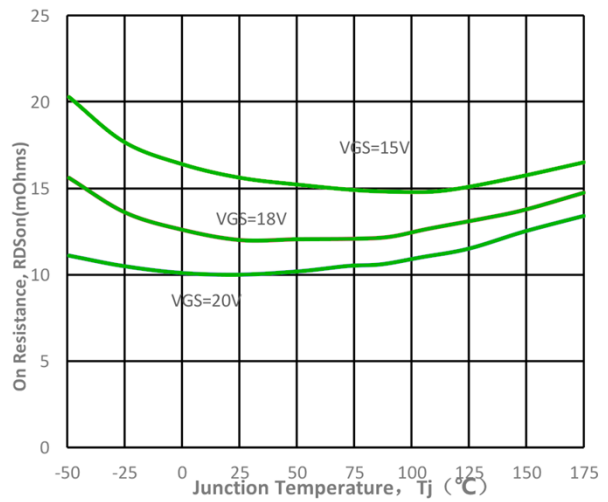

Fig4. On-Resistance vs. Temperature

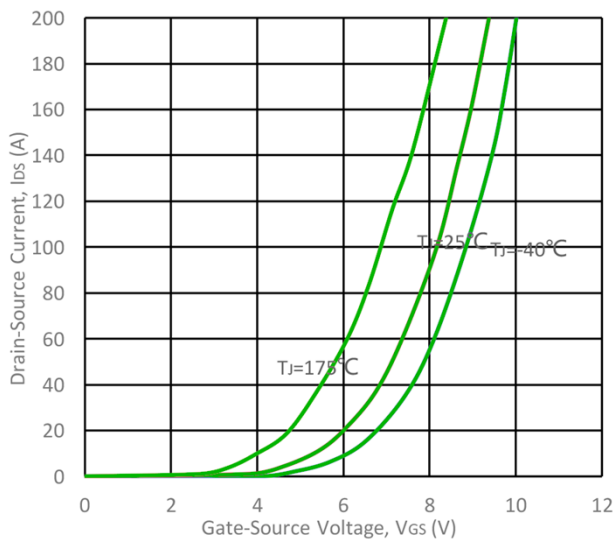

Fig5. Transfer Characteristic

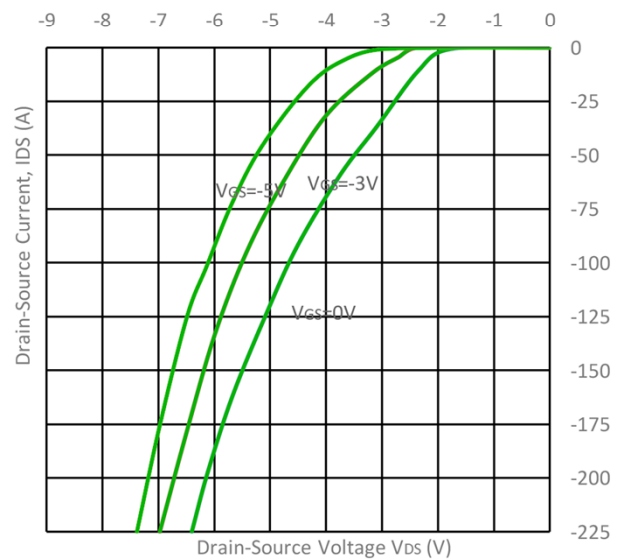

Fig6. Body Diode Characteristic at $25\text{ }^\circ\text{C}$

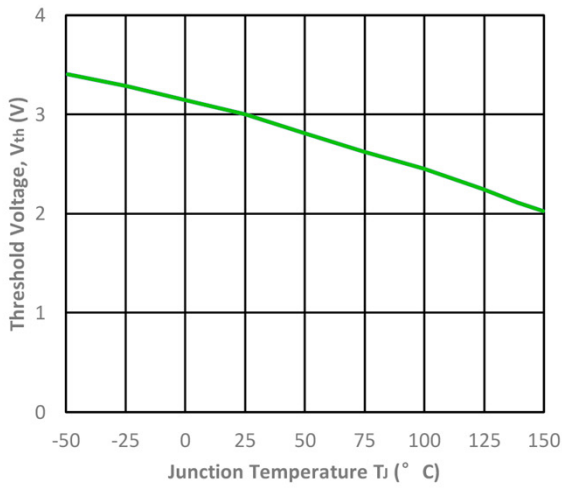

Fig7. Threshold Voltage vs. Temperature

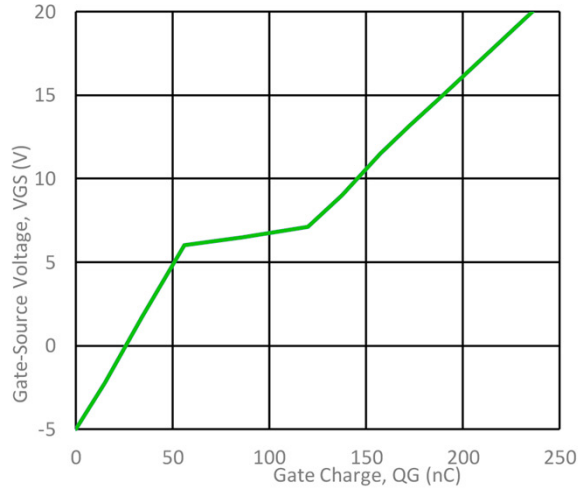

Fig8. Gate Charge Characteristics

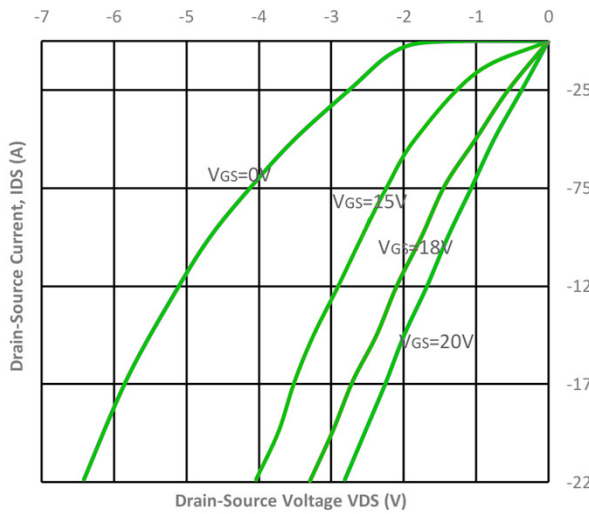

Fig9. 3rd Quadrant Characteristic at 25 °C

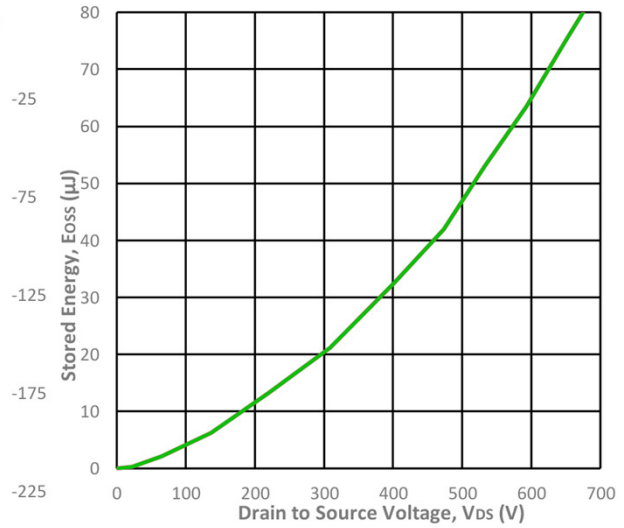

Fig10. Output Capacitor Stored Energy

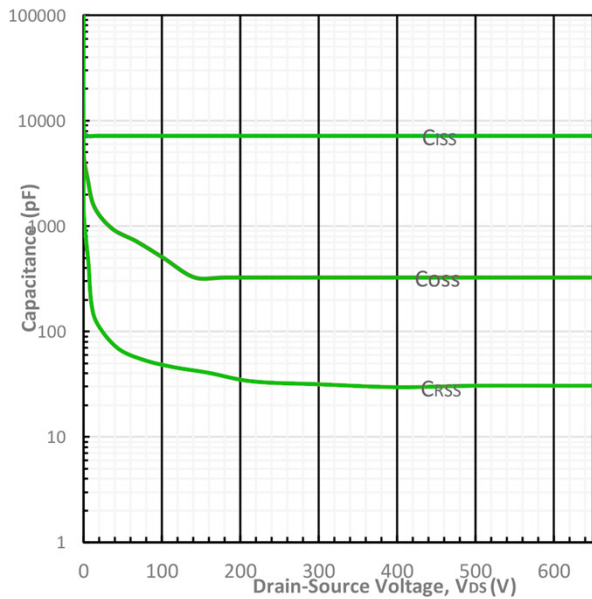

Fig11. Capacitances vs. Drain-Source

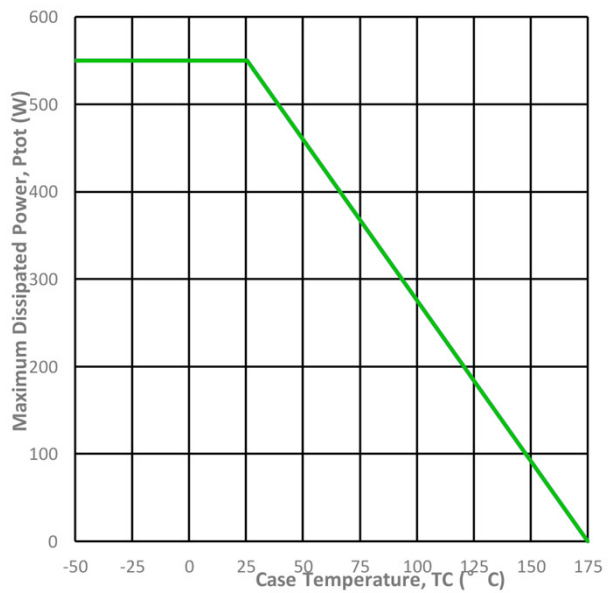

Fig12. Max Power Dissipation Derating Vs Tc

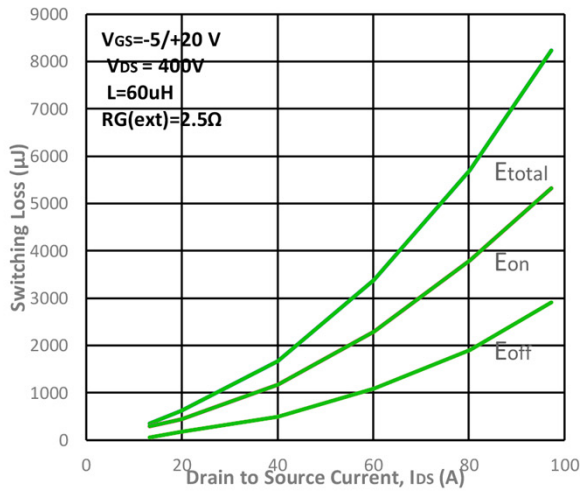

Fig13. Switching Energy vs. Drain Current

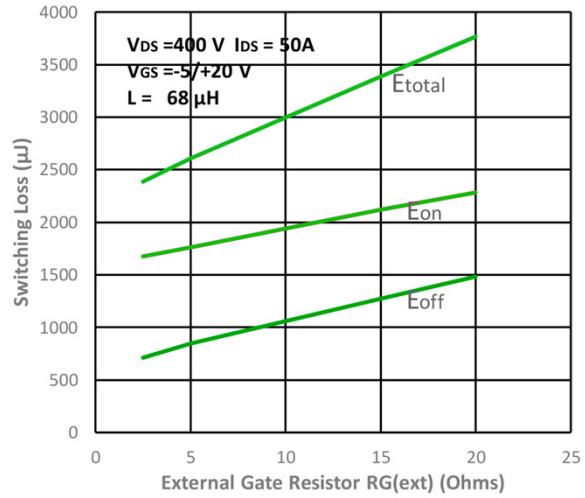

Fig14. Switching Energy vs. $R_{G(ext)}$

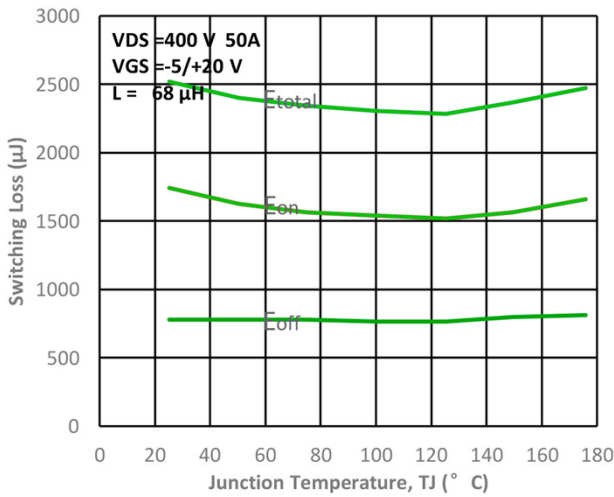

Fig15. Switching Energy vs. Temperature

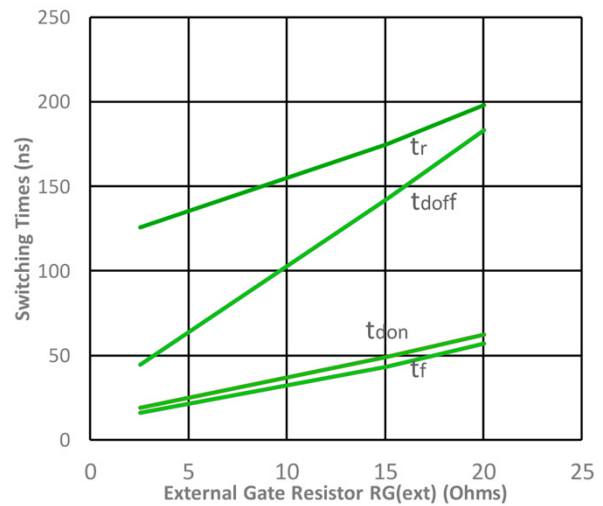

Fig16. Switching Times vs. $R_{G(ext)}$

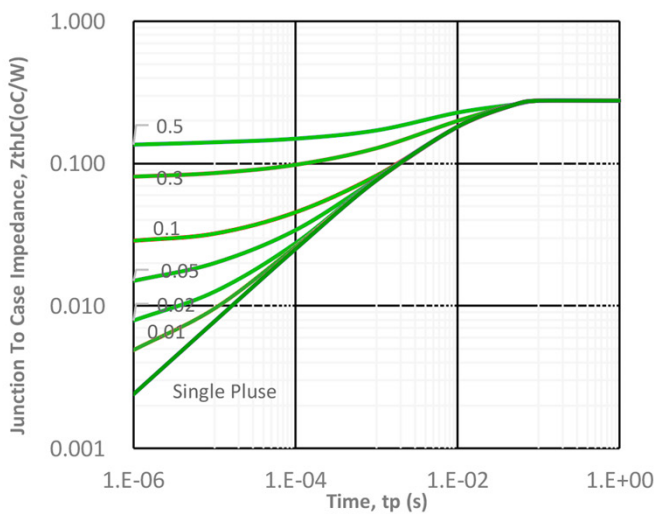

Fig17. Transient Thermal Impedance

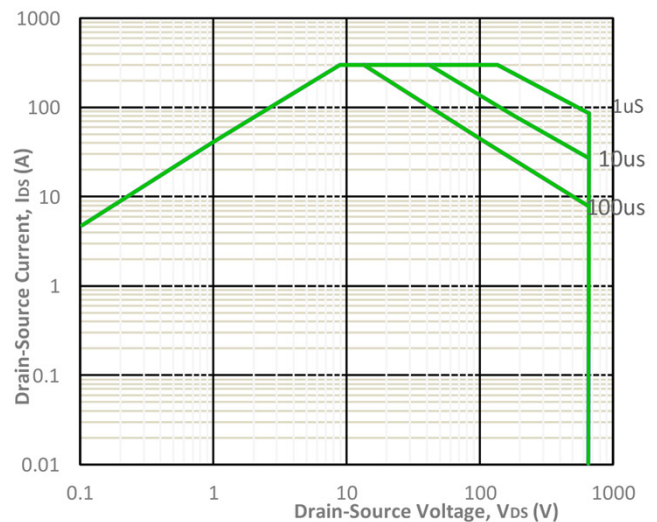
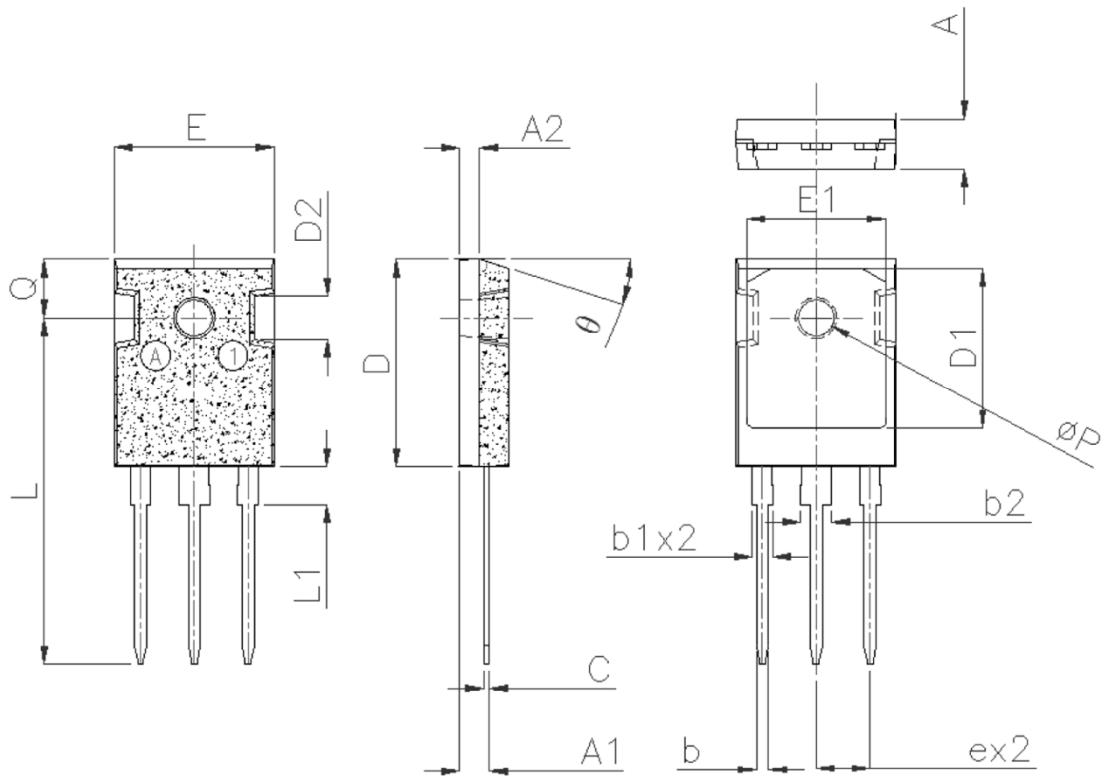



Fig18. Safe Operating Area

Product dimension (TO-247-3L)



Dim	Millimeters		Inches		Dim	Millimeters		Inches	
	Min	Max	Min	Max		Min	Max	Min	Max
A	4.80	5.20	0.189	0.205	e	5.44 BSC		0.214 BSC	
A1	2.85	3.15	0.112	0.124	E	15.95	16.35	0.628	0.644
b	1.16	1.27	0.046	0.050	E1	13.82	14.26	0.544	0.561
b1	2.03	2.10	0.080	0.083	L	34.65	35.45	1.364	1.396
b2	3.03	3.10	0.119	0.122	L1	-	3.86	-	0.152
C	0.55	0.65	0.022	0.026	Q	5.85	6.05	0.230	0.238
D	20.80	21.20	0.819	0.835	φP	3.45	3.75	0.136	0.148
D1	15.94	16.54	0.628	0.651	θ	17.5°		17.5°	
D2	4.30 BSC		0.169 BSC						

IMPORTANT NOTICE

 and **Prisemi**[®] are registered trademarks of **Prisemi Electronics Co., Ltd** (Prisemi), Prisemi reserves the right to make changes without further notice to any products herein. Prisemi makes no warranty, representation or guarantee regarding the suitability of its products for any particular purpose, nor does Prisemi assume any liability arising out of the application or use of any product or circuit, and specifically disclaims any and all liability, including without limitation special, consequential or incidental damages. "Typical" parameters which may be provided in Prisemi data sheets and/or specifications can and do vary in different applications and actual performance may vary over time. All operating parameters, including "Typicals" must be validated for each customer application by customer's technical experts. Prisemi does not convey any license under its patent rights nor the rights of others. The products listed in this document are designed to be used with ordinary electronic equipment or devices, Should you intend to use these products with equipment or devices which require an extremely high level of reliability and the malfunction of with would directly endanger human life (such as medical instruments, aerospace machinery, nuclear-reactor controllers, fuel controllers and other safety devices), please be sure to consult with our sales representative in advance.

Website: <http://www.prisemi.com>

For additional information, please contact your local Sales Representative.

©Copyright 2009, Prisemi Electronics

 **Prisemi**[®] is a registered trademark of Prisemi Electronics.

All rights are reserved.